



Description

CNG manifolds provide pressure control, monitoring and distribution for high pressure compressed natural gas installations.

We have incorporated our tried and tested designs of valve and pressure regulator into a compact manifold. This offers significant improvements in terms of installation footprint and minimisation of potential leak paths over traditional panels using discrete components.

The valves are of a cartridge or insert configuration and can be removed and replaced easily without disturbing the manifold block.

Check valves are fitted inside the manifold block.

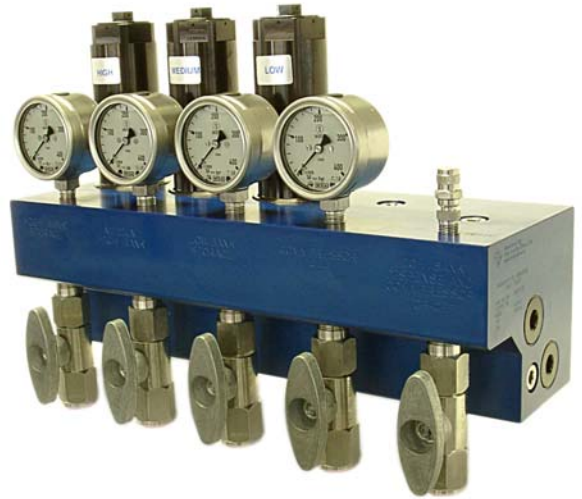

Standard Specification

- Nominal Bore: 12mm
- Maximum inlet pressure: 400bar
- Nominal flow rate: 800 N m³/hr at 10 bar ΔP
- Weight approx. 21 kg
- Filtration requirement: 20 micron
- Temperature range: -20 to +70°C

Options

Please contact us for details

- Pneumatically operated isolation valves can be supplied
- Integrated filtration can be supplied
- Ports: alternative port configurations can be supplied
- Materials: suitable combinations of materials can be supplied for various applications.
- Certification: ATEX to category 3

Standard Materials

Alternative materials can be supplied

- Manifold and main valve components: Anodised Aluminium Alloy
- Elastomers: Viton
- Valve seats: PEEK

Ordering Information

Please supply the following information when ordering

- Outlet pressure range
- Number of outlets
- Flow medium
- Port configuration
- Pneumatically operated isolation valves
- Integrated filtration
- Operating and storage temperature ranges
- Certification and QA requirements

We design, machine, build and test all our products on one site in Uxbridge. If you don't see what you want in our standard ranges, contact us and we'll do our best to meet your needs.

Hale Hamilton (Valves) Ltd
Cowley Road, Uxbridge, UB8 2AF, UK
Tel: 01895 236 525
www.halehamilton.com



P & ID

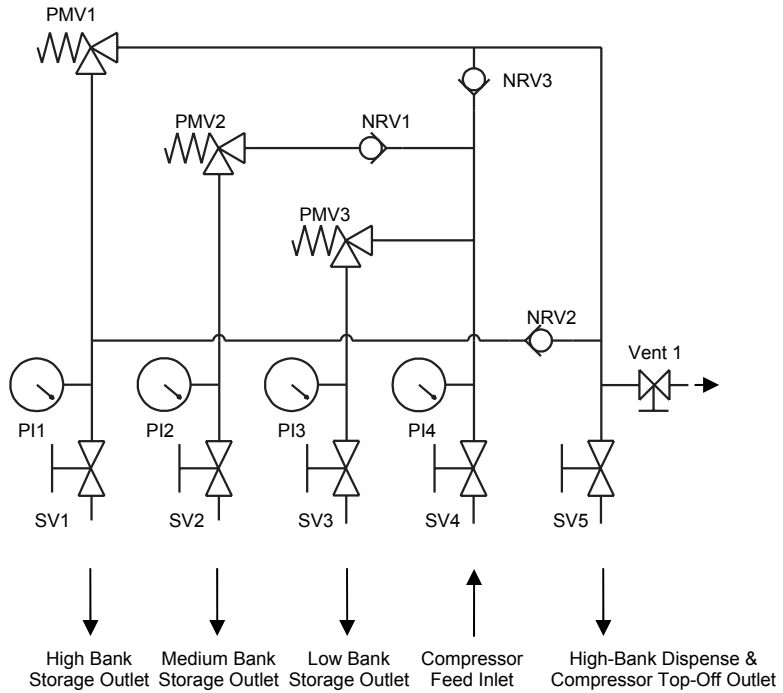

Typical Dimensions

in mm except where shown otherwise

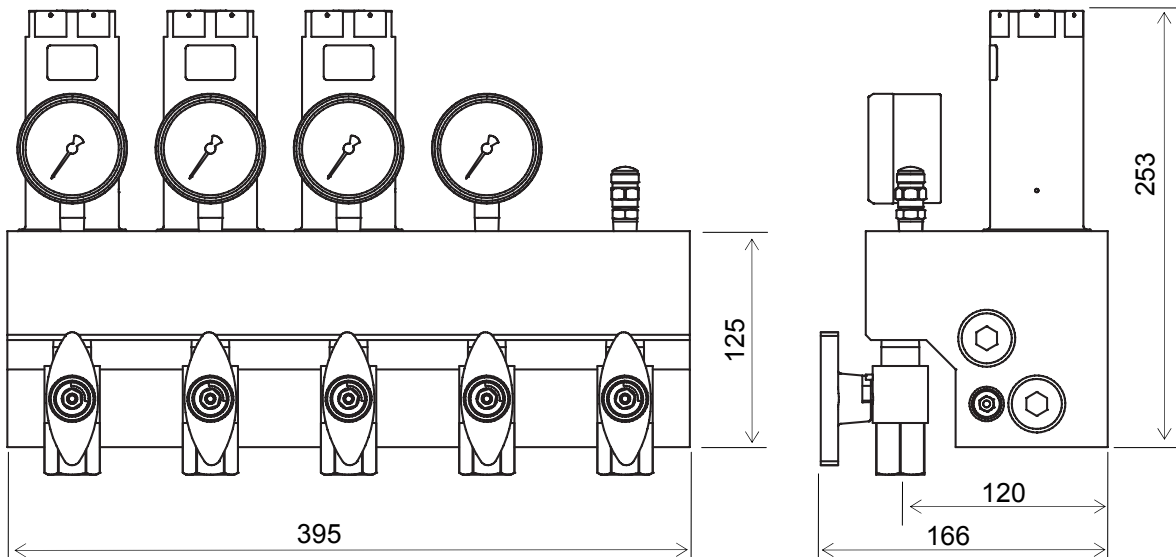

We design, machine, build and test all our products on one site in Uxbridge. If you don't see what you want in our standard ranges, contact us and we'll do our best to meet your needs.

Hale Hamilton (Valves) Ltd
Cowley Road, Uxbridge, UB8 2AF, UK
Tel: 01895 236 525
www.halehamilton.com